

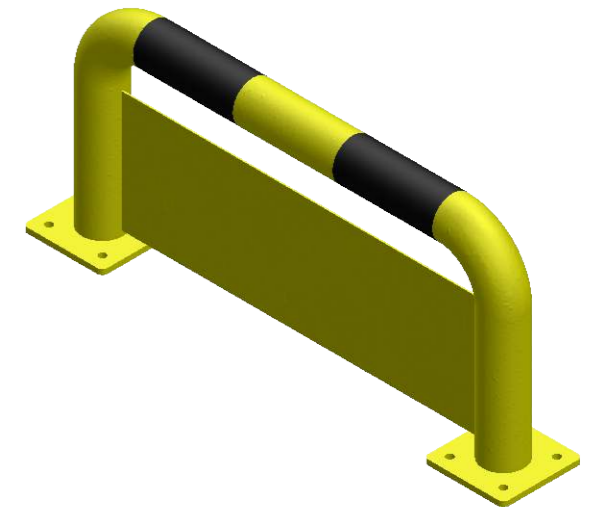

REV	REVISION NOTES	REVISION BY	REVISION DATE
1			
2			
3			
4			

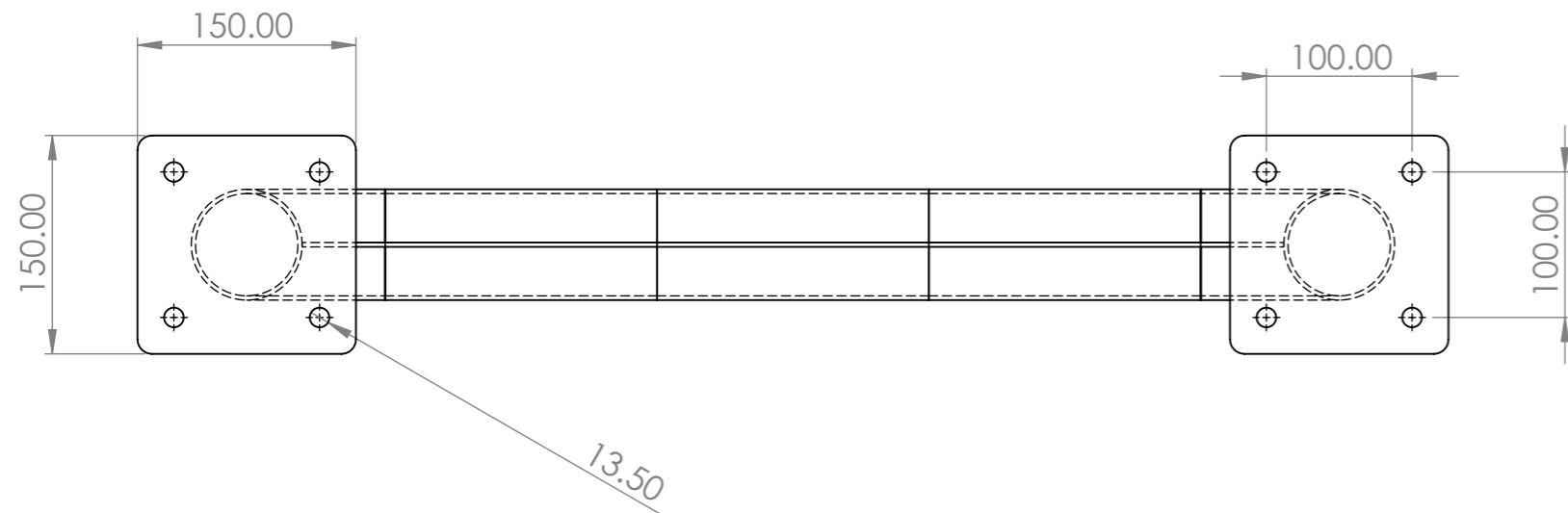
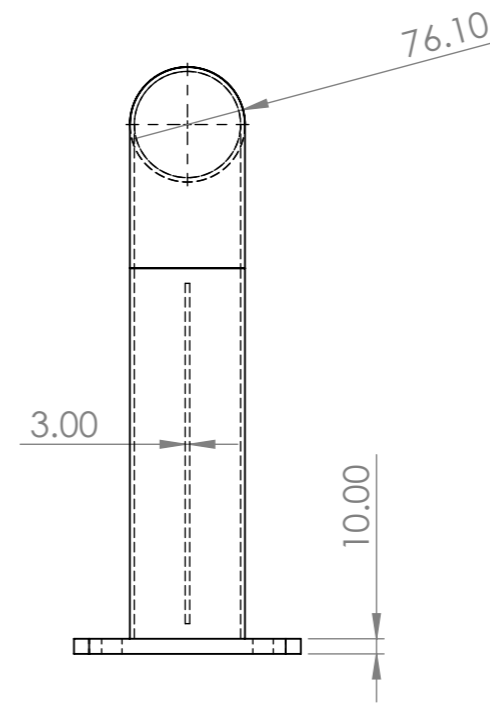
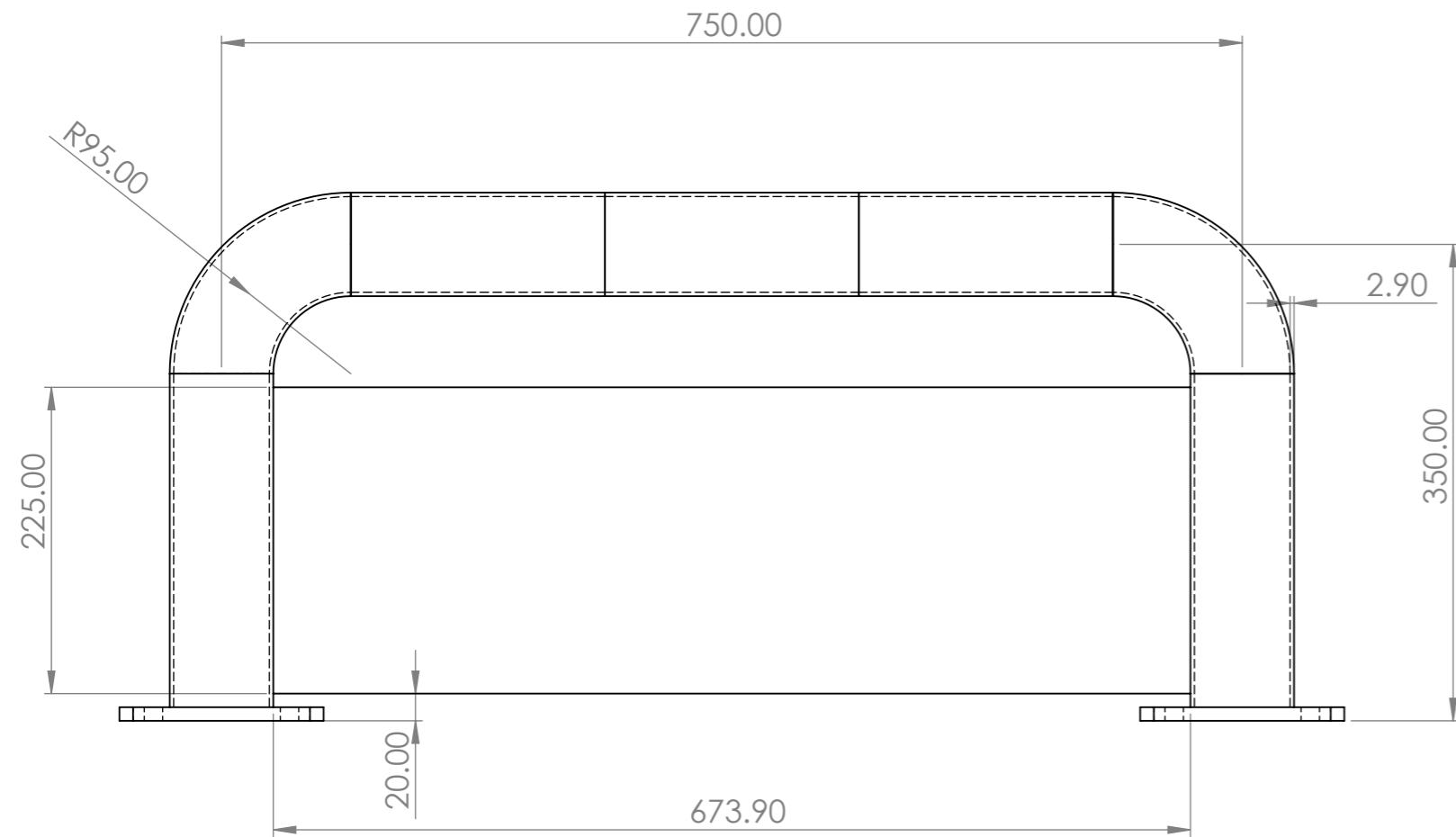

 <p>METAL PRODUCTS DIRECT</p>	UNLESS OTHERWISE SPECIFIED: DIMENSIONS ARE IN MILLIMETERS TOLERANCES: X: 2.5 X.XX: 0.13 X.X: 0.25 X.XXX: 0.013		CUSTOMER:	
	MATERIAL: Plain Carbon Steel		DESCRIPTION: Straight Guard With Infill L750mm x H350mm	
17 Bridge Street Pendlebury Manchester M27 4DU	FINISH: Powder coated WEIGHT: 13.97 Kg	BY: _____ DATE: _____	DWG NO: SGWI-L750-H350-D76	
DEBUR AND BREAK SHARP EDGES DO NOT SCALE DRAWING IF IN DOUBT ASK!	DRAWN: LH CHECKED: _____ APPROVED: _____	SHEET SCALE: 1:5 SHEET SIZE: A3 SHEET NUMBER: 1 OF 1	REV: _____	