

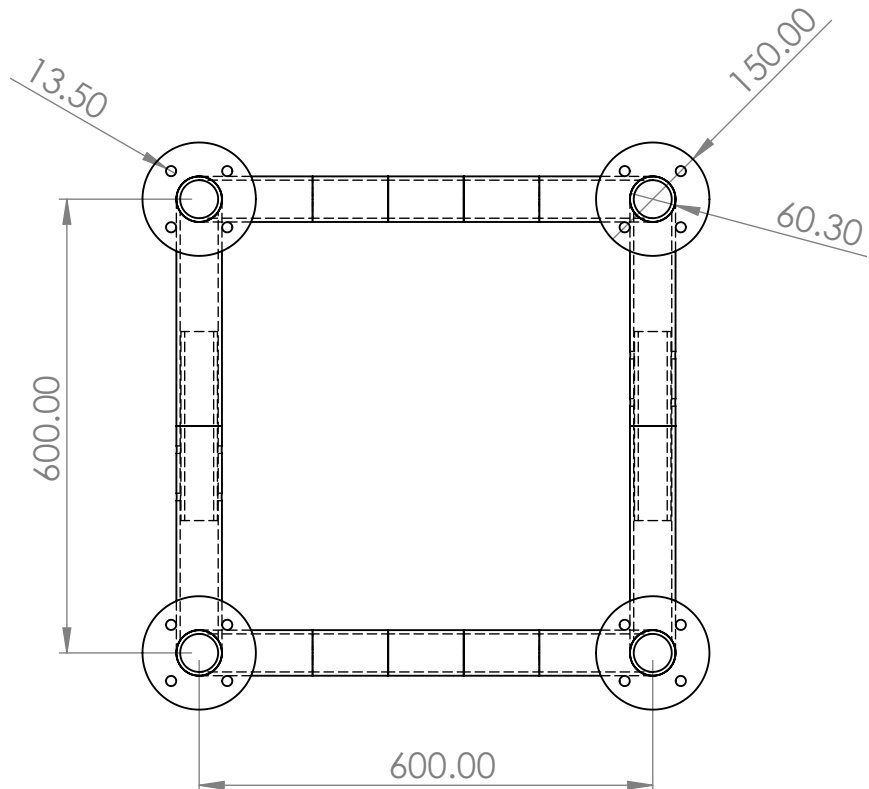

REV	REVISION NOTES	REVISION BY	REVISION DATE
1			
2			
3			
4			

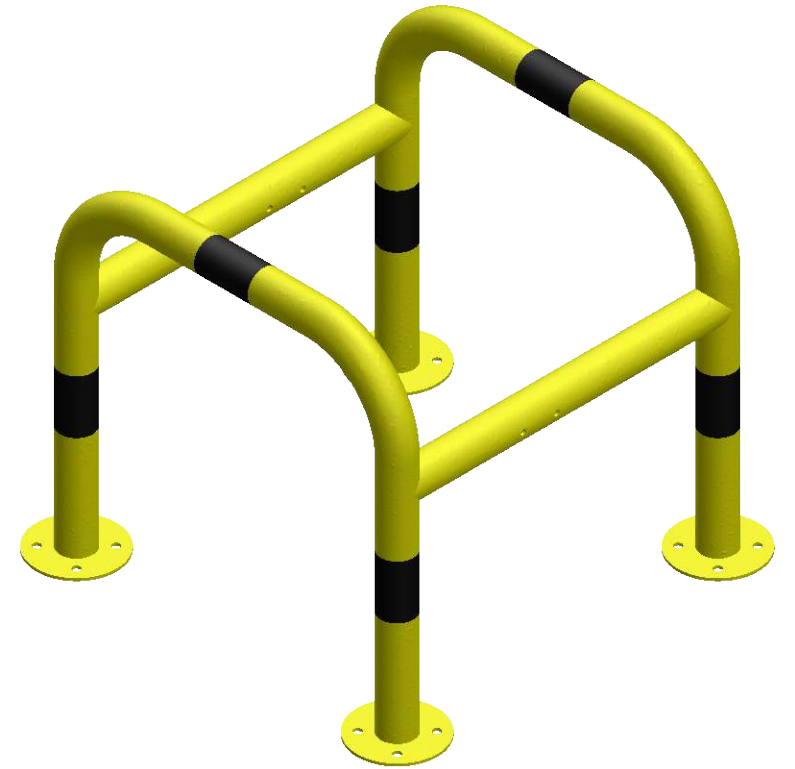
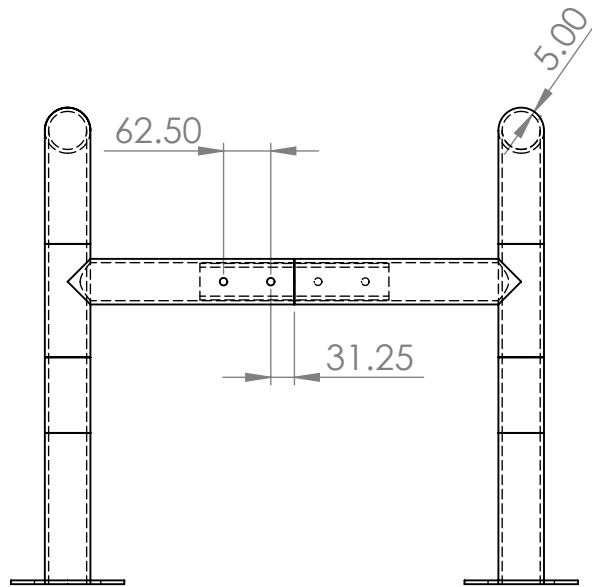
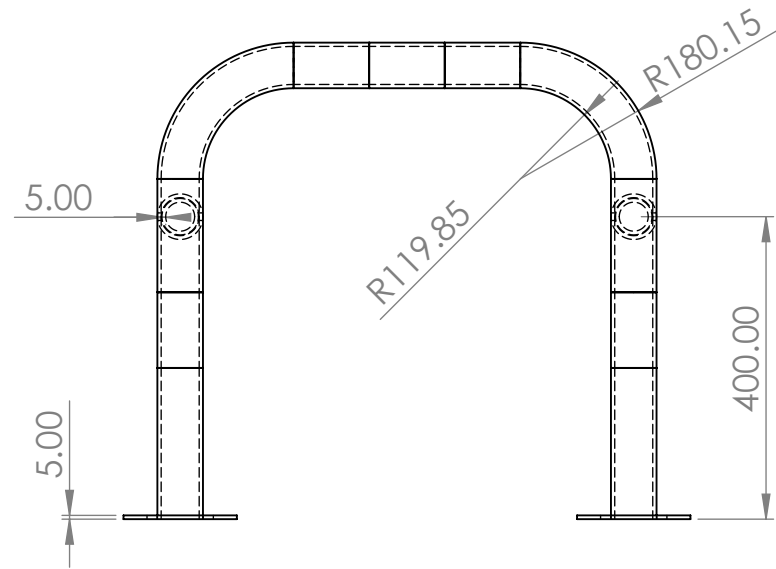
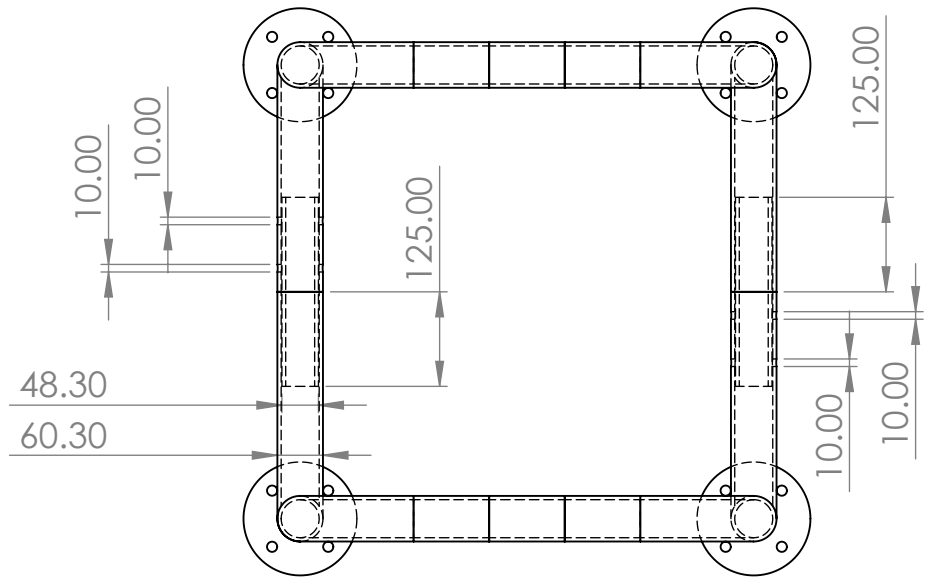

 METAL PRODUCTS DIRECT	UNLESS OTHERWISE SPECIFIED: DIMENSIONS ARE IN MILLIMETERS TOLERANCES: X: 2.5 X.XX: 0.13 X.X: 0.25 X.XXX: 0.013	CUSTOMER:	
	MATERIAL: Mild Steel	DESCRIPTION: Lamp post protection	
17 Bridge Street Pendlebury Manchester M27 4DU	FINISH: Powdercoated WEIGHT: Kg 35.34	DWG NO: LPP-PC-H600-L600	REV:
DEBUR AND BREAK SHARP EDGES DO NOT SCALE DRAWING IF IN DOUBT ASK!	BY: _____ DATE: _____ DRAWN: _____ CHECKED: _____ APPROVED: _____	SHEET SCALE: 1:10	SHEET SIZE: A3 SHEET NUMBER: 1 OF 1